

V Series

FEATURES

- Compact design, substantial space saving
- Simple assembly
- CE approved types

The essential features of the thumb-wheel switch are its high reliability, precision and contact endurance.

Interswitch thumbwheel switches are used in machine tool control systems, measurement and test units, control and regulation systems, computer systems, sound and vision control systems, telecommunications, medical measurement systems, etc.



SPECIFICATIONS

Rates current (resistive load)	1-75 mA AC/DC		
Max. current carrying capacity	0.5 A AC/DC		
Max. working voltage	max. 42 V AC/DC		
Test voltage	250 V DC		
Insulation resistance (+20°C)	10 ⁵ MOhm		
Contact resistance (ind. PCB)	70 MOhm		
Servicelife (switch operations)	min. 10 ⁵		
Permissible ambient temp.	-25° ... +70°C		
10 positions	Yes	Direct solder connections	Yes
16 positions	Yes	Edge connections	Yes
Decimal	Yes	Solder pins	Yes
Binary	Yes	Wire wrap pins	Yes
Binary + Complement	No	Front mounting	Yes
PCB for diode mounting	Yes		



Interswitch Thumbwheel Switches – V Series

Dimensions	
Width in mm	8
Height in mm	26.5
Mounting depth in mm	min. 38
Character height in mm	3.5

Top View

n = Number of modules without end brackets
(1 pair of division plates 1 element)

Front View

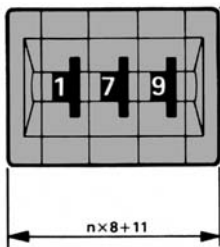

Panel Cut-Out

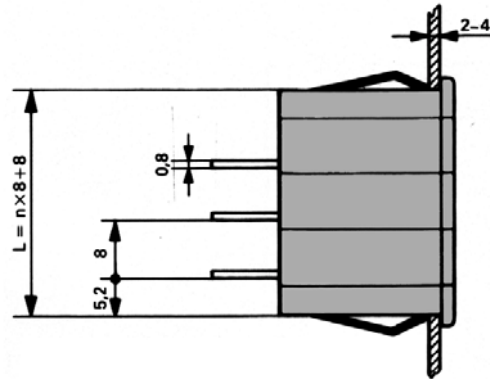
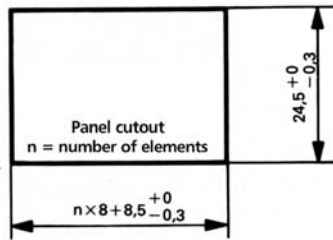

Side View

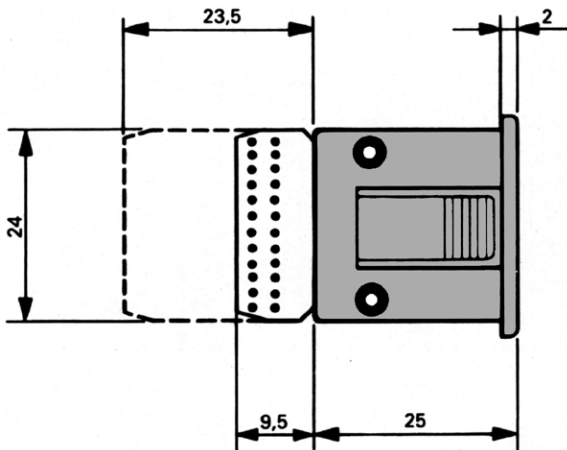

PCB Design

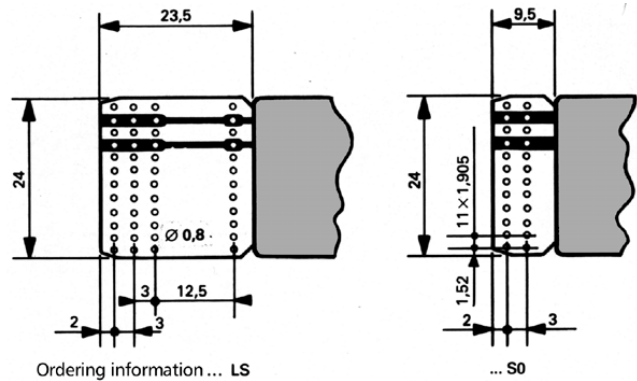

Division Plates and End Brackets

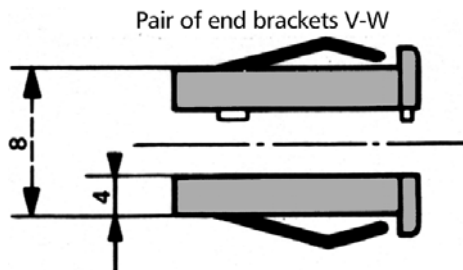
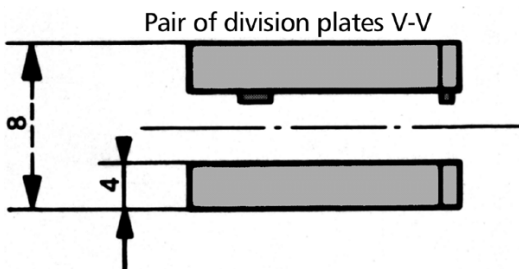

Code 010

Decimal 0-9

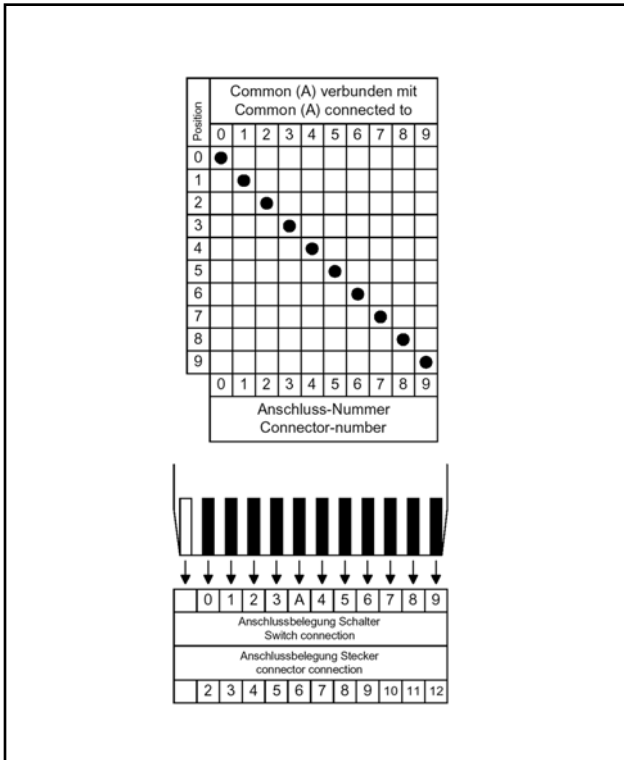

Code 140

BCD + 2 Inputs

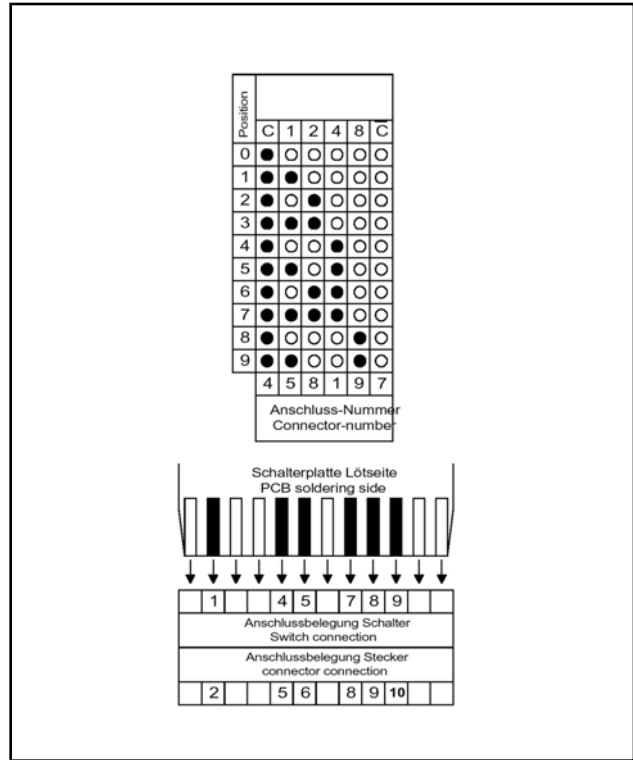

Code 627

Hexadezimal

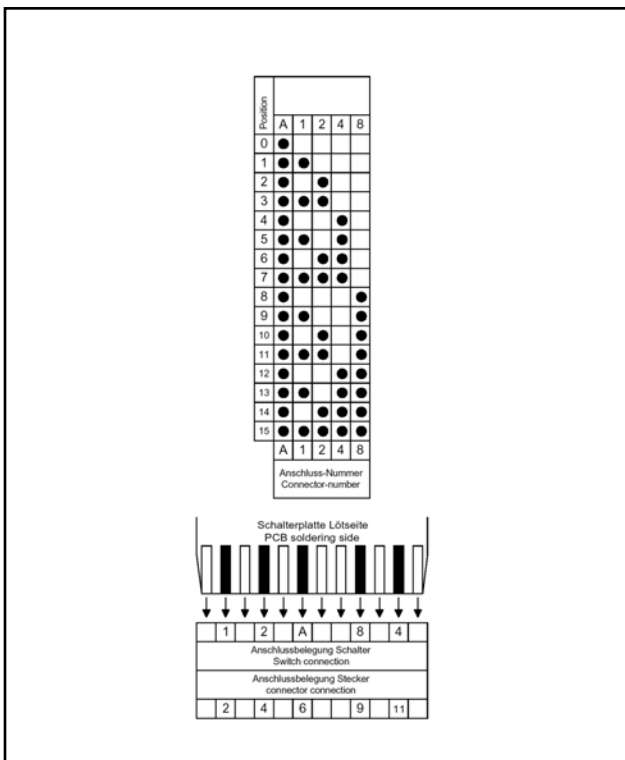

Code 632

Resistance decade

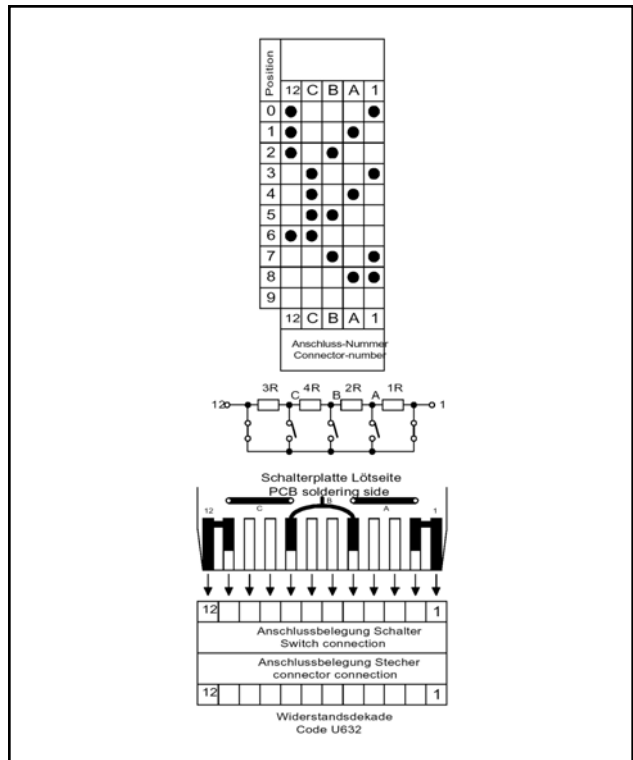



Interswitch Thumbwheel Switches – V Series

Code 701

Single pole change over switch

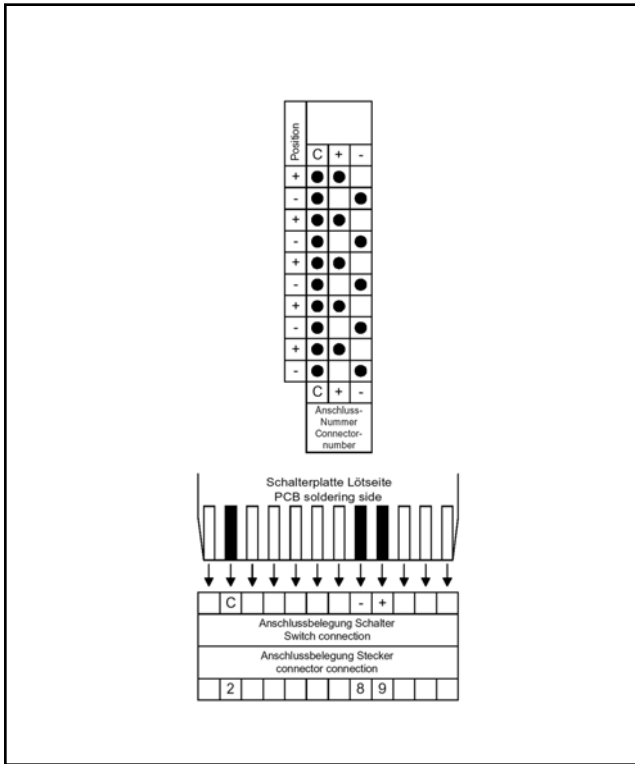

Code 731

BCD Positive

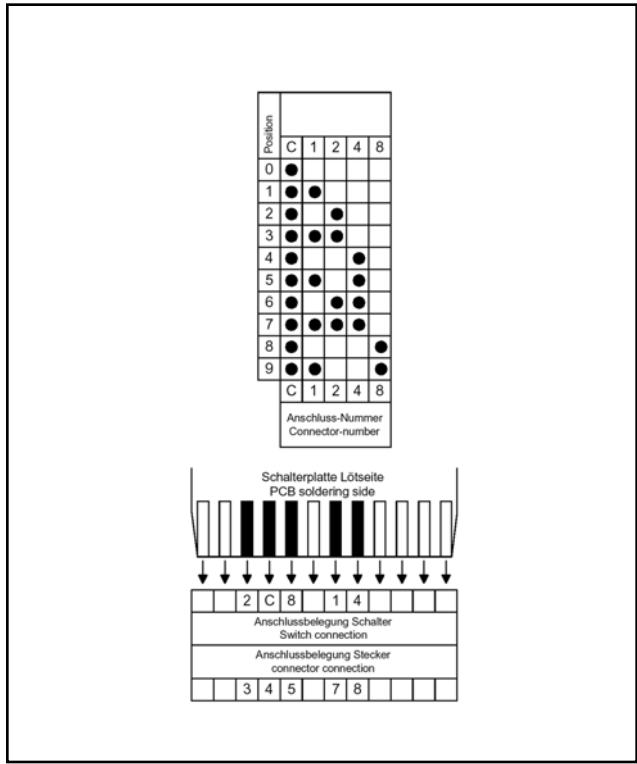

Code 861

BCD negative

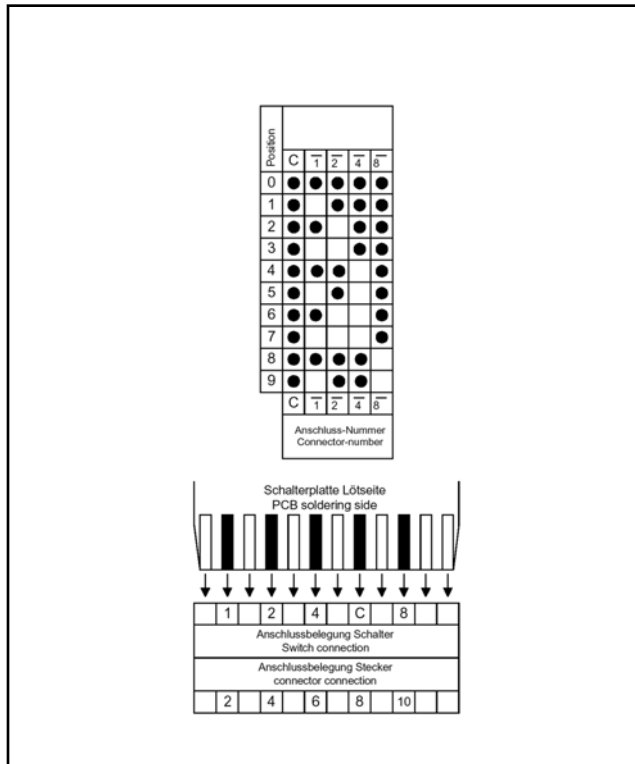

Product specifications contained herein may be changed without prior notice. It is therefore advisable to contact Purdy Electronics before proceeding with the design of equipment incorporating this product.